

SFH551/1-1 Integrated Photo Detector Receiver for Plastic Fiber
SFH551/1-1V Plastic Connector Housing

Features

- Bipolar IC with open-collector output
- Digital output, TTL compatible
- Sensitive in visible and near IR range
- Low switching threshold
- Transfer rate ≤ 5 Mbit/s
- 2.2 mm aperture holds standard 1000 micron plastic fiber
- No fiber stripping required
- Molded microlens for efficient coupling

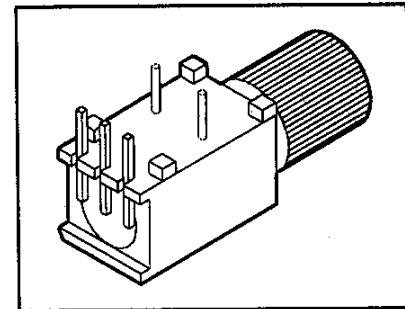
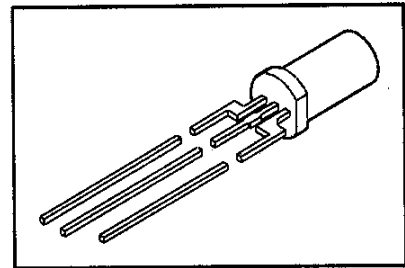

Plastic Connector Housing

- Mounting screw attached to the connector
- Interference-free transmission from light-tight housing
- Transmitter and receiver can be flexibly positioned
- No cross talk
- Auto insertable and wave solderable
- Supplied in tubes

Applications

- Household electronics
- Power electronics
- Optical networks
- Medical instruments
- Automotive electronics

Type	Ordering Code
SFH551/1-1	Q62702-P3180
SFH551/1-1V	Q62702-P3181

Block Diagram

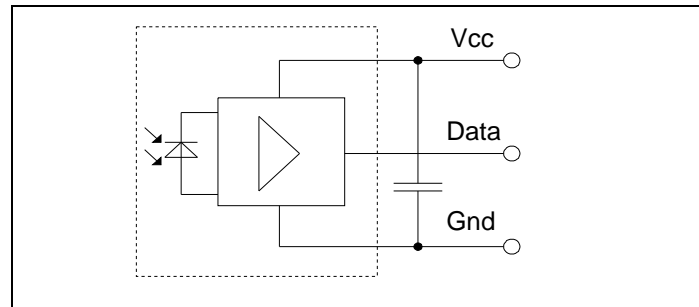

A bypass capacitor (100 nF) near the device (distance ≤ 3 cm) is necessary between ground and V_{CC} . In critical applications the distance may be shorter.

Description

The SFH551/1V is a transimpedance amplifier with digital TTL open collector output stage and integrated photodiode. The active area of the detector in connection with the molded microlens gives an efficient coupling from the end of a plastic fiber.

The receiver is fully DC coupled and therefore no line code is needed.

The SFH551/1V includes a Schmitt trigger function to provide stable output states over the whole dynamic range. With noise free V_{CC} and GND no undefined output signal is possible

SFH551/1 must not be used without shielding the ambient light, because ambient light causes malfunction when reaching the threshold level, noise or complete switching the output. Interference free transmission is possible by using the SFH551/1V with the black plastic connector housing.

Absolute Maximum Ratings

Parameter	Symbol	Values	Unit
Operating Temperature Range	T_{OP}	-40 to +85	$^{\circ}C$
Storage Temperature Range	T_{STG}	-55 to +100	$^{\circ}C$
Soldering Temperature (2 mm from case bottom $t \leq 5$ s)	T_S	260	$^{\circ}C$
Supply Voltage Range without Damage	V_{CC}	-0.5 to 15	V
Minimum Supply Voltage for Function	V_{CCmin}	4	V
Minimum Pullup Resistance ($V_{CC}=5$ V)	R_{outmin}	330	Ω
Output Voltage	V_O	-0.5 to 15	V
Output Current	I_O	50	mA
Power Dissipation (output)	P_O	100	mW

Characteristics ($T_A = 25^\circ\text{C}$, $V_{CC} = 4.75$ to 5.25 V)

Parameter	Symbol	Values	Unit
Maximum Photosensitivity Wavelength	λ_{Smax}	700	nm
Photosensitivity Spectral Range ($S=80\% S_{max}$)	λ	600 to 780	nm
SFH551/1-1 Optical threshold power ($\lambda=660$ nm)	Φ_{INth}	≤ 6 ≤ -22	μW dBm
Maximum optical power ($\lambda=660$ nm) maximum value of t_{pLH} at maximum power !	Φ_{INL}	1000 0	μW dBm
Optical power for output high without errors ($\lambda=660$ nm)	Φ_{INH}	≤ 0.1 ≤ -40	μW dBm
Propagation delay (optical input to electrical output, with fast optical pulse)	t_{pHL}	< 100	ns
	t_{pLH}	< 250	ns
Current Consumption (without output current)	I_{CC}	4	mA

Package Outlines (dimensions in mm, unless otherwise specified)

SFH551/1-1

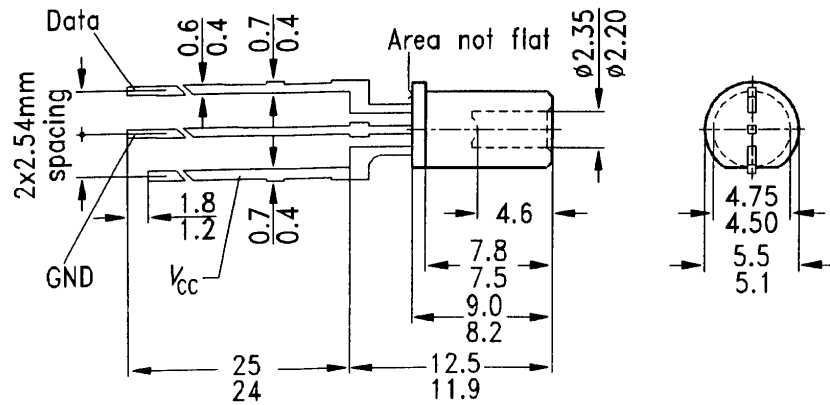

SFH551/1-1V

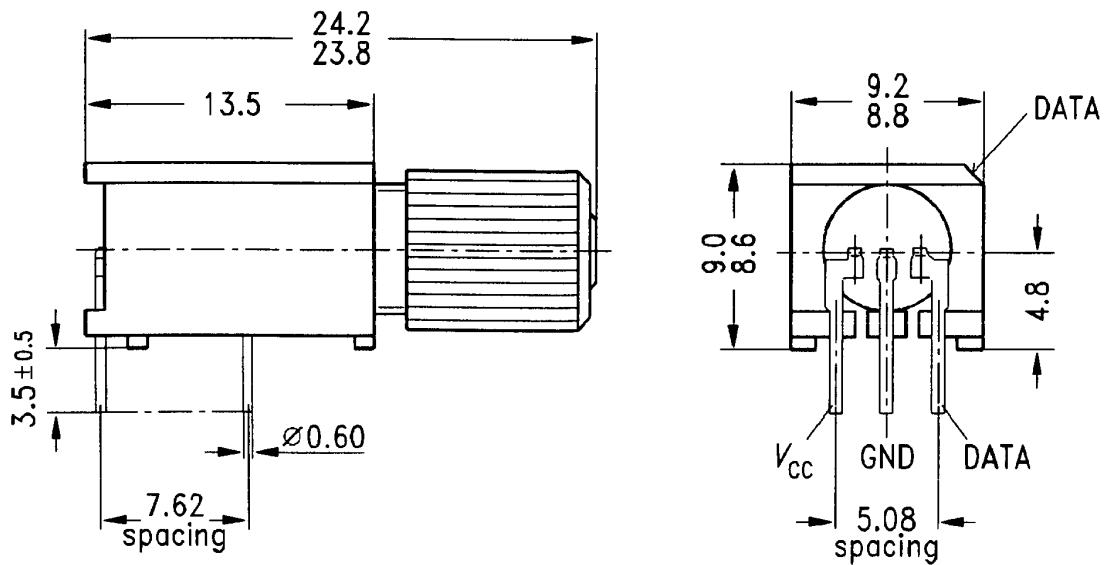

Published by Infineon Technologies AG

**© Infineon Technologies AG 2002
All Rights Reserved**

Attention please!

The information herein is given to describe certain components and shall not be considered as warranted characteristics.

Terms of delivery and rights to technical change reserved.

We hereby disclaim any and all warranties, including but not limited to warranties of non-infringement, regarding circuits, descriptions and charts stated herein.

Infineon Technologies is an approved CECC manufacturer.

Information

For further information on technology, delivery terms and conditions and prices please contact the Infineon Technologies offices or our Infineon Technologies Representatives worldwide - see our webpage at www.infineon.com/fiberoptics

Warnings

Due to technical requirements components may contain dangerous substances. For information on the types in question please contact your Infineon Technologies offices.

Infineon Technologies Components may only be used in life-support devices or systems with the express written approval of Infineon Technologies, if a failure of such components can reasonably be expected to cause the failure of that life-support device or system, or to affect the safety or effectiveness of that device or system. Life support devices or systems are intended to be implanted in the human body, or to support and/or maintain and sustain and/or protect human life. If they fail, it is reasonable to assume that the health of the user or other persons may be endangered.

Infineon Technologies AG • Fiber Optics • Wernerwerkdammm 16 • Berlin D-13623, Germany
Infineon Technologies, Inc. • Fiber Optics • 1730 North First Street • San Jose, CA 95112, USA
Infineon Technologies K.K. • Fiber Optics • Takanawa Park Tower •
20-14, Higashi-Gotanda, 3-chome, Shinagawa-ku • Tokyo 141, Japan